



io7 Installation Guide



Thank you for choosing the io7

Ratio EV Charging
Unit 1 Target Park
Shawbank Road
Lakeside
Redditch
Worcestershire
United Kingdom
B98 8YN

+44 (0) 1527 396 900

info@ratioev.uk
sales@ratioev.uk
technical@ratioev.uk

ratioev.uk

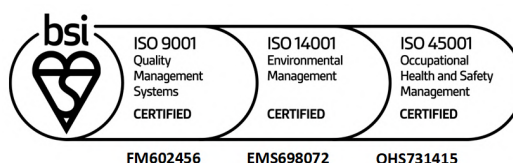

Preface

About this document

This manual contains technical descriptions and instructions for the following product:

Category of product	Electric Vehicle Charger
Product name	io7
Art. No.	io7xxx
Serial number:	
Ad hoc password:	
Charger password:	

Please refer to Ratio's T&C's at ratioev.uk

This manual contains all instructions and safety information for installation, commissioning, use and maintenance of the product.

This manual is intended for:

- the qualified electrician who installs the product;
- the end-user who uses the charger;
- the product owner who maintains the product.

Copyright

The content of this manual is protected by copyright and other intellectual property laws. The content of this manual may only be copied, modified, reproduced or translated with express written permission from the manufacturer. This manual may only be published, transmitted, displayed or made available to a third party with express written permission from the manufacturer.

Disclaimer of liability

Ratio EV Charging cannot be held responsible for personal injury, damage to the product or property damage caused by incorrect use, foreseeable misuse or failure to follow the instructions in this manual. This also applies to unauthorized modifications of the product and the use of non-approved spare parts, tools or accessories.

Ratio EV Charging reserves the right to modify this manual without notification beforehand.

Table of contents

1.	Safety	5
1.1.	Symbols and labels	5
1.1.1.	Safety warnings	5
1.1.2.	Notices	5
1.1.3.	Fuel Identifier	6
1.2.	Intended use	7
1.3.	Reasonably foreseeable misuse	7
1.4.	Qualification of personnel	7
1.5.	Personal Protective Equipment	7
1.6.	Safety precautions	8
2.	Product description	9
3.	Technical data	10
3.1.	Product Labelling/Marking	13
4.	Transport and Storage	13
4.1.	Transport	13
4.2.	Storage	14
5.	Installation	14
5.1.	Preparation	14
5.1.2.	Required tools	14
5.1.3.	Required wiring and electrical protection	14
5.2.	Install the power cable in the distribution board	15
5.3.	Installing the io7	15
6.	Commissioning the io7	18
6.1.	Initial Steps	18
6.1.2.	General Information Page	22
6.1.3.	CSMS	22
6.1.4.	Network Settings/Parameters	23
6.1.5.	4G Enabled	25
6.1.6.	Ethernet Enabled	25
6.1.7.	SIM Enabled	26
6.1.8.	Installer Settings	27
6.1.9.	Smart Charging	29
6.2.	Back-end software Provider	30
7.	io7 Power up	30
8.	Troubleshooting	31
9.	Use	32
9.1.1.	Start Charging through back-end software	32
9.1.2.	Start Charging RFID	32
9.2.	During charging	32
9.2.1.	Charging paused	32
9.3.	Stop charging	32
10.	Maintenance	33
11.	Service	33
12.	Data protection	33
13.	Warranty	33
14.	Disposal	34
15.	EC Declarations of Conformity	35

1. Safety

Please make sure the instructions have been fully read and understood before commencing the installation or use of the product. Failure to follow the instructions from this manual can put people, surroundings, the environment and product at risk. Store this manual securely for future reference.



Always comply with the information, such as labels and the nameplate, attached directly to the product and keep the information in a legible condition.

Always comply with any applicable laws and regulations that have not been accounted for in this manual for example IET regulations.

1.1. Symbols and labels

1.1.1. Safety warnings

This manual contains safety warnings that may result in injury if ignored. Each safety warning is indicated with a safety identifier. The identifier corresponds with the level of risk of the described hazardous situation, see the table below.

Safety Identifier	Risk of injury	Result when instruction is ignored or not followed correctly
 WARNING	Medium	Could result in death or serious injury
 CAUTION	Low	Could result in minor or moderate injury

Safety warnings at the start of a section apply to the entire section.

Safety warnings that refer to a particular sentence or procedure step are embedded in the running text.

1.1.2. Notices

Messages that are not hazard-related are indicated with the safety identifier **NOTICE**. These messages do not have a safety alert symbol.

Signal word	Meaning
NOTICE	Could result in damage to the product when instruction is ignored or not followed correctly.
Note	Additional information or emphasis on an instruction.

1.1.3. Fuel Identifier

The Fuel Identifier symbol is located at the front of the charger by each socket.

This is to inform the user the fuel type (electricity) produced by this charger and to instruct which end of the Electric Vehicle charging cable is to be plugged into the socket of the charger.

The socket on the io7 receives the Plug end (as illustrated below) of the cable which should be indicated with a smaller similar graphical illustration which can be either silver or white in colour. The vehicle end of the charging cable should have a small black Fuel Identifier.

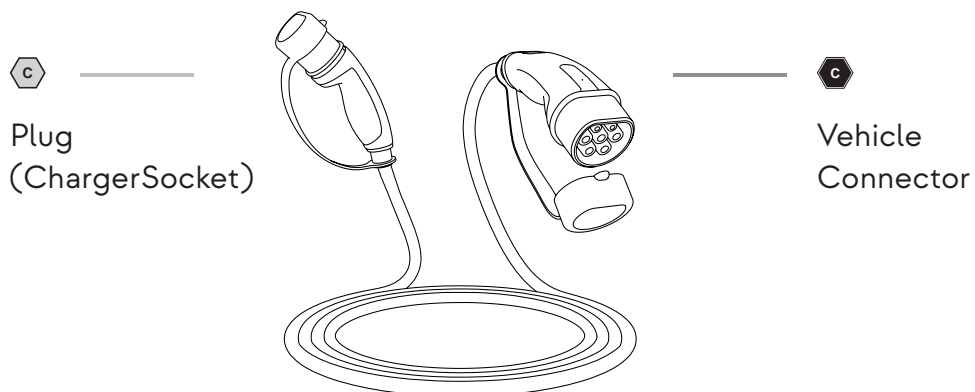
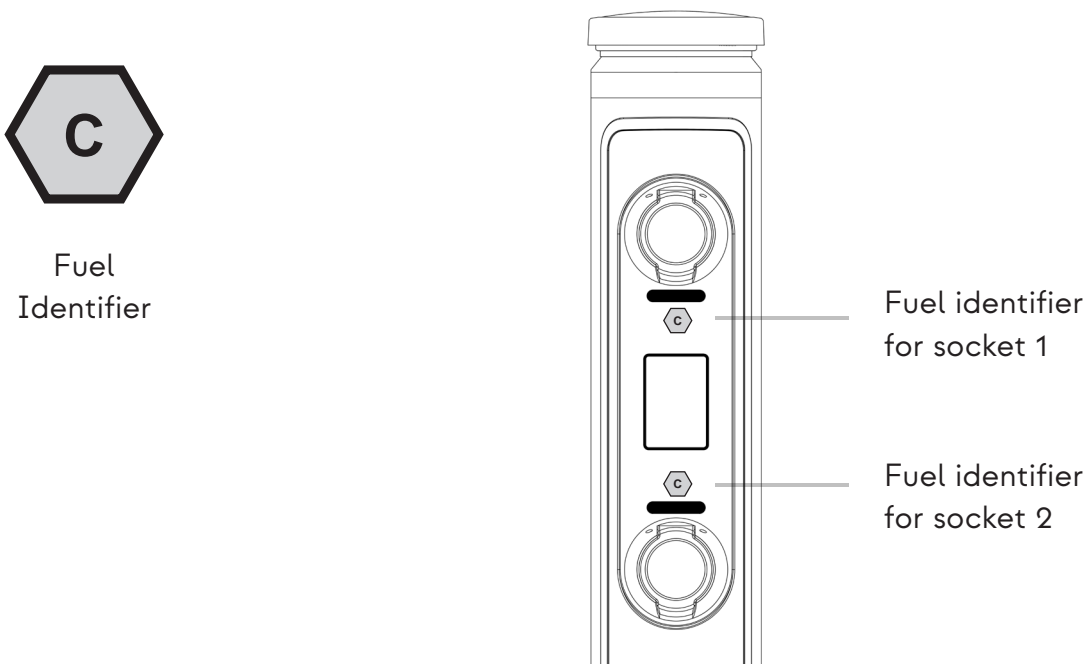

1.2. Intended use

The io7 is a restricted charger intended to charge electric vehicles using power from the main electrical supply network. The product is intended for outdoor use only.

The product must only be operated within its performance limits and under the permitted ambient conditions, as stated in the technical specifications in chapter 3.

The product should only be mounted flush to the floor (non-insulating and with drainage). Safe use of the product is only guaranteed if it is used as intended.

1.3. Reasonably foreseeable misuse

The following is considered foreseeable misuse:

- Use in an environment that varies from or exceeds the given environmental conditions.
- Use that varies from or exceeds the given operating conditions.
- Failure to comply with the instructions in this manual.
- Failure to eliminate faults, malfunctions or defects of the product that impose safety risks.
- Failure to carry out the inspections and maintenance operations as described in this manual.
- Unauthorised removal or modification of parts or safety devices of the product.
- Use of spare parts or accessories that have not been approved by the manufacturer.
- Operation in a flammable and/or explosive environment.

1.4. Qualification of personnel

Only qualified electricians are allowed to perform installation and maintenance of the product. They must meet the below stated criteria;

- are of legal age.
- are familiar and abide by the safety instructions and sections of this manual related to installation and maintenance of the product.
- are familiar with and abide by the applicable local, national and international laws and regulations.
- are able to recognise the possible dangers of the product and take the necessary measures to protect persons and property.
- have received adequate training in the safe installation and maintenance of this product.
- hold the relevant qualifications.

1.5. Personal Protective Equipment

NOTICE

Wear the appropriate Personal Protective Equipment (PPE) according to the manual of any tools used during installation of the charger.

Wear insulating gloves when installing wires and touching electrical components to avoid damaging the product by static discharge.

1.6. Safety precautions

Despite the safe design and construction of the product and the prescribed protective measures, the product possesses residual risks. This manual provides safety messages to indicate these risks. The formatting and appearance of safety messages that are dedicated to a particular section or sentence is explained in chapter 1.1.

Read all the safety warnings and instructions before using the product. Failure to follow the warnings and the instructions may result in electric shock, fire and/or serious injury.

WARNING

- Do not put fingers into the electric vehicle connector.
- Do not use this product if the flexible power cord or EV cable are frayed, have broken insulation, or show any other signs of damage.
- Do not use the product if the enclosure or EV connector are broken, cracked, open, or show any other indication of damage.
- The electrical installation must be isolated during the entire installation period.
- Improper connection of equipment-grounding conductor can result in a risk of electric shock. Check with a qualified electrician if you doubt whether the product is properly grounded.
- Do not use this product if it does not function according to the instructions in this manual. Seek advice from Ratio, your vendor, or a qualified electrician.
- Do not attempt to remove the charging plug while a charging session is active.
- Children should not be allowed to use this product. Do not allow children to play near the product. Children should be supervised when using this device around them.
- The installation must be conducted by a qualified electrician in line with local and national legislation and IET regulation.
- Open PEN fault protection is incorporated into single and three phase io7 charger variants.

CAUTION

- Ensure the supply cable of the product is positioned so it will not be stepped on, tripped over, or otherwise subjected to damage or stress.
- There are no user serviceable parts inside. Refer to the Customer Support section in this manual for service information. Do not attempt to repair or service the product yourself.
- Only use this product to charge electric vehicles equipped with a conductive charge port. See the vehicle owner's handbook to determine the vehicle is equipped with a conductive charge port.
- Use of any adaptors is not allowed with this product.
- Only use certified Type 2 charging cables with this product.
- Cord extension sets are not allowed to be used.

NOTICE

- Do not drop the product and avoid impacts.
- Do not store the product in an environment that exceeds the ambient conditions stated in this manual.
- Do not expose the internal components of the product to moisture.
- Do not immerse the product in water or any other liquid.

2. Product description

The io7 is a Mode 3 charger for charging electric vehicles (EVs) which complies with the IEC61851 series of standards.

The io7 incorporates professional lighting systems which have been designed in accordance to BS EN 60598-1 and BS EN 62196.

The io7 is equipped with several features to optimise power consumption and charging performance.

Over the air (OTA) updates

The io7 charger is equipped with the technology to receive over the air updates, enabling your charger to receive the available updates over the internet through a back-end software management platform.

The io7 must be used in conjunction with a back-end software management platform, such as Monta or Fuuse. This will allow full visibility over the charger use, energy consumption etc.

Charging Mode	To be configured through the back-end software such as Monta or Fuuse. These will commonly be private, public or schedule.
----------------------	--

3. Technical data

Product name	io7
Art. no.	io7xxx
Charging System	IEC61851, Mode 3
Cable version car connector	IEC 62196, Type 2
Outlet version	IEC 62196, 2 x Type 2 Outlets
Power input	Single-phase or three-phase, 230V-400V AC, 16A-32A
Power output	Output 7.4 kW / 230V AC, 22 kW / 400V AC
Frequency	50 Hz
Protection against electric shock	Class I
Protections	AC 30mA and DC 6mA
Surge Protection	Surge Protection 4kV
Rated peak withstand current (IPK)	≤80 kA2s
Rated short-time withstand current (Icw)	N/A
Rated conditional short circuit current (Icc)	5000A ² s
Rated diversity factor	
Pollution degree	Pollution Degree 4
Compatible earthing systems	TN, IT, TT
EMC classification	EN 61851-21-2;2021 Residential & Non-Residential EN 55032:2015 + A1:2020 Class B ENSI EN 301 489-1 V2.2.3:2019 EN 300 328 V2.2.2:2019 EMC Directive 2014/30/EU & UK Electromagnetic compatibility Regulations 2016
Housing	Polyester Powder Coated Aluminium
Dimensions	1410mm × 230mm × 230mm
Weight	17 kg
Country of Manufacture	United Kingdom
Enclosure rating	IP54/IK08
Ambient temperature	-25°C to +30°C
Markings	CE & UKCA
Earthing	PME fault detection on single and three phase versions
Ventilation	Not supported
Metering	CT Clamp or MID meter versions available
Required protection device type	Type A (refer to table in section 5.1.3)
Supported connectivity protocols	Wi-Fi 4G Ethernet
RFID	Included 13.56MHz
Standards	BS EN IEC 61851-1 BS EN 60598-1 BS EN 62196 BS 7671:2018+A2:2022
EV Communications	OCPP 1.6J

Note: The io7 will connect to most back-end software platforms (e.g. Monta or Fuuse) for visibility over charger usage, performance and fault reporting.



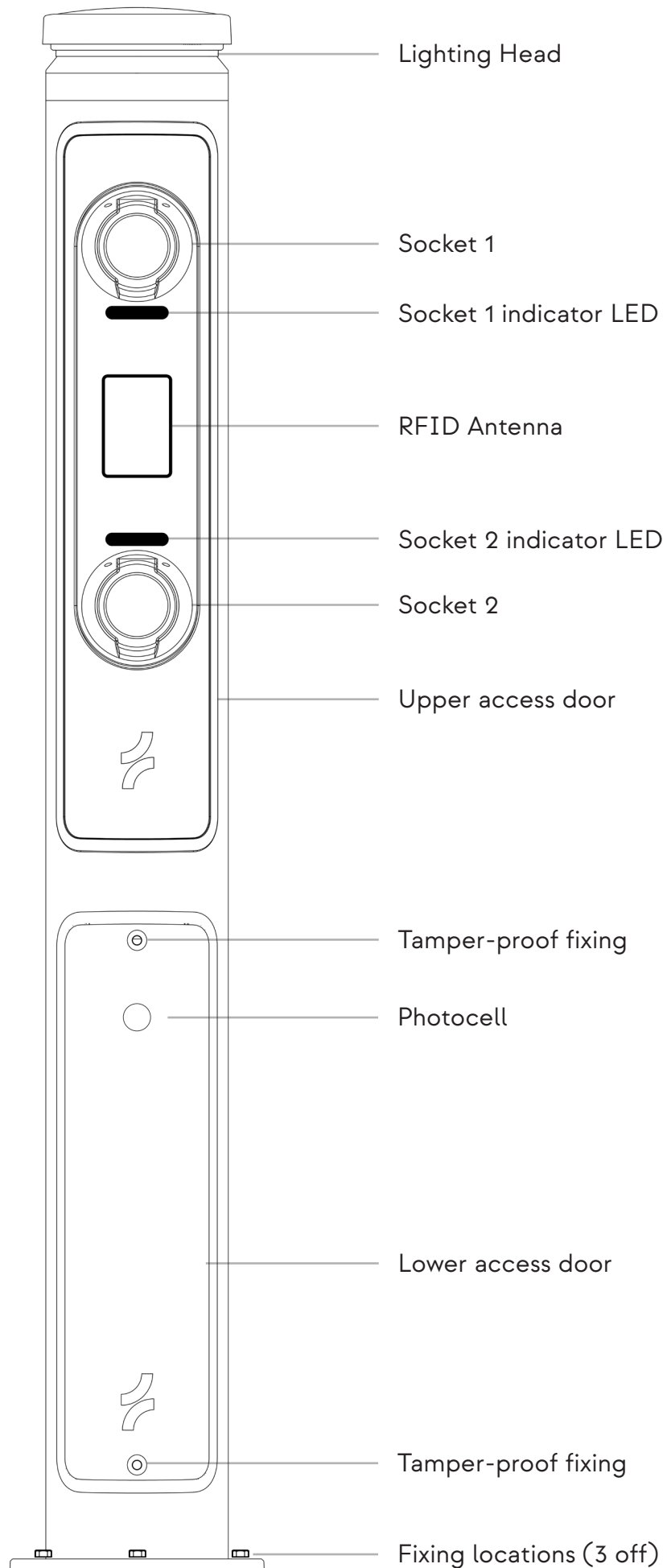

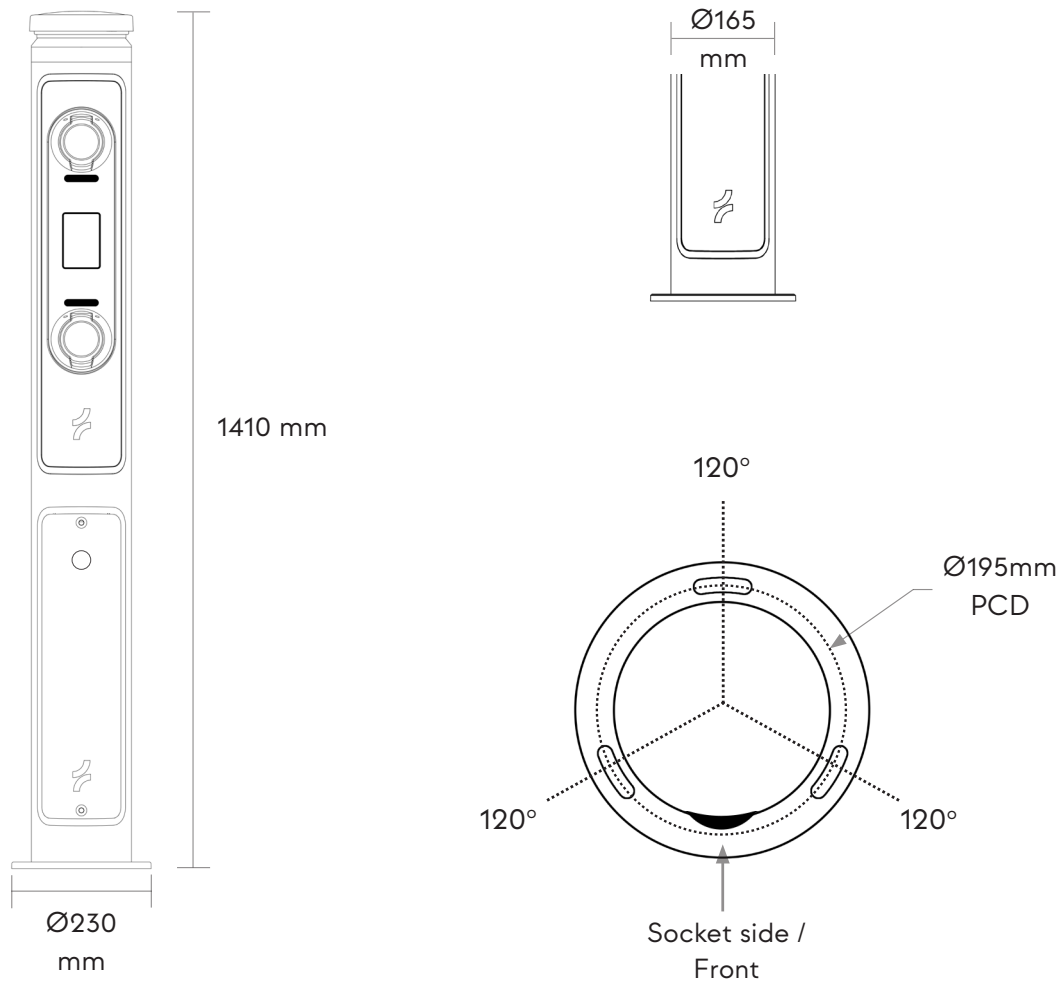

io7





LED Colour Description

The LEDs on the io7 provides the user with a visual representation of the chargers status. Please see below the table with the colour and the status description.

	LED Colours	Status
	White	Boot up
	Green	Ready
	Magenta	Cable inserted
	Yellow	Waiting to charge
	Blue (Pulsing)	Charging
	Blue (Solid)	Charging delayed
	Red	Fault (See table in page 31)

Note: If the LEDs are **Red**, the fault will be reported via OCPP to the back-end software. Consult the back-end software fault logs, or if the problem persists contact Ratio for remote assistance.

3.1. Product Labelling/Marking

The product is marked in accordance with the applicable legislative requirements. All product labels are located on the mounting plate within the protective cover in the inside of the main housing behind the lower access door.



RFID Indicator

Socket 1

Socket 1

Ⓧ N L1

Earth, Neutral & Live 1

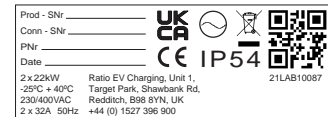

**Product Information
Commissioning QR Code
Serial Number
WEEE
AC Supply
IP54**

Socket 2

Socket 2

Ⓧ N L1 L2 L3

**Earth Neutral
Live 1 Live 2
Live 3**



Warning - Isolate before removing cover

RS485 Socket 1

RS485 Socket 1



Safety Electrical connection - Danger High Voltage

RS485 Socket 2

RS485 Socket 2



Fuel Identifier

4. Transport and Storage

4.1. Transport

Transport the product in the original packaging, or suitable replacement that provides adequate protection from vibrations, impacts, moisture, dust, and debris.

Ensure to not drop the product and prevent it from impacts.

Excessive vibrations could loosen connections and cause product malfunction.

4.2. Storage

Store the product in the original packaging or a suitable replacement packaging to protect the product from moisture, dust, and debris.

Do not store anything on top of the product.

5. Installation

5.1. Preparation

⚠ WARNING

- The installation must be done by a qualified electrician in accordance with local and national legislation and IET regulations.
- The electrical installation must be isolated during the entire installation period.
- Since this charging unit uses circuits that reference to ground, no insulation resistance testing should be conducted on the unit after connecting to the supply network.

5.1.2. Required tools

- Spirit level
- Flat-head screwdriver size 3
- HM5 Pin Hex Allen key
- Suitable equipment for ground fixings (M10 advisable)

5.1.3. Required wiring and electrical protection

Note: On Ethernet versions a Data cable will be required.

Charger Model	Recommended supply cable ¹	Internal RCBO	Residual Current Device (RCD) at source ²
Twin 7.4kW	3 core 16mm ²	2 x 40A Type A 30mA 2 pole	63A, 150mA time delayed / 300mA Type A minimum 2 pole
Twin 11kW	5 core 10mm ²	2 x 20A Type A 30mA 4 pole	32A, 150mA time delayed / 300mA Type A minimum 4 pole
Twin 22kW	5 core 16mm ²	2 x 40A Type A 30mA 4 pole	63A, 150mA time delayed / 300mA Type A minimum 4 pole

- 1 - For cable lengths up to 25m and in accordance with table 4E4A of BS7671.
- 2 - Ensure RCD is compliant with BS EN 61008-1 and switches all poles (including neutral).

5.2. Install the power cable in the distribution board

1. The electrical installation must be isolated during the entire installation period. Do not use the io7 until the installation has been completed.
2. Lay down a power cable and data cable (optional) between the distribution board and the installation location of the charger.
3. It is advised to connect the charger to your internet through Wi-Fi. Alternatively, you can connect via 4G or through the use of an Ethernet cable to gain internet connectivity.
4. For circuit protection devices please refer to section 5.1.3
5. Connect the power cable wires to the dedicated protection devices in the distribution board.

5.3. Installing the io7

1. Prepare the foundations of the ground prior to installing the io7, ensuring it is free from debris as well as any possible water accumulation that may occur.

⚠ WARNING

The io7 should **never** be mounted onto an insulating material unless an earth electrode is installed.

Flange Mount - Anchor Bolts

The surface mounting foundation adaptor can be used to secure the charger to the existing concrete (or similar) surfaces, or to a purpose laid 600 x 600 x 200mm concrete pad.

The surface mounting plate is secured to the ground using three M10 x 150mm (minimum) expanding countersunk concrete anchor bolts (not provided) or preferred equivalent fixing.

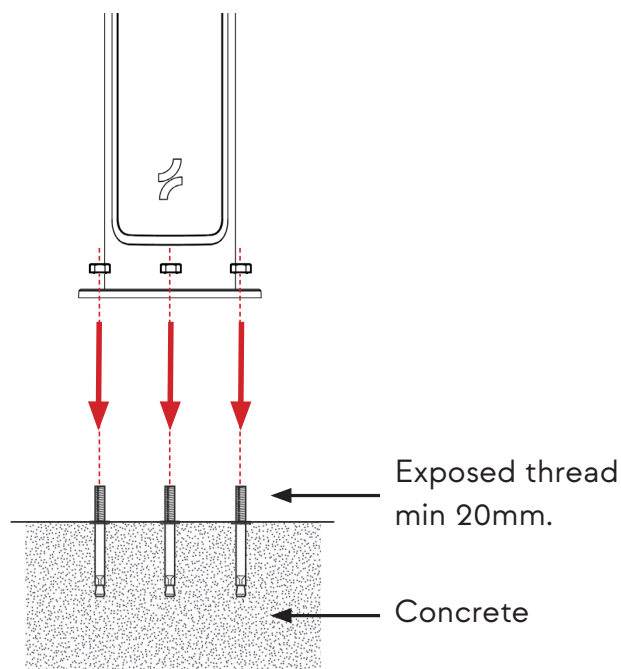

Flange Mount - J-Bolts

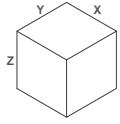

Foundation Dimensions	
	Flange Mount
X	400 mm
Y	400 mm
Z	300 mm

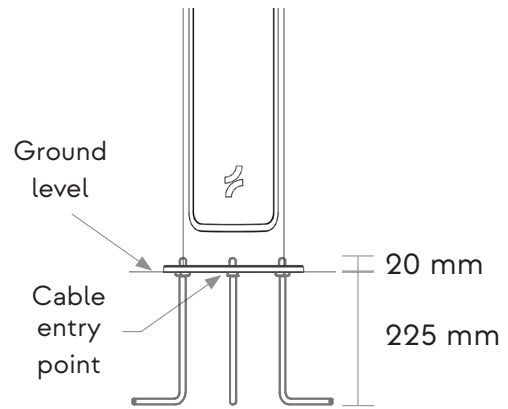

- Place the io7 securely onto the fixings and use a spirit level to ensure the io7 is mounted vertically.

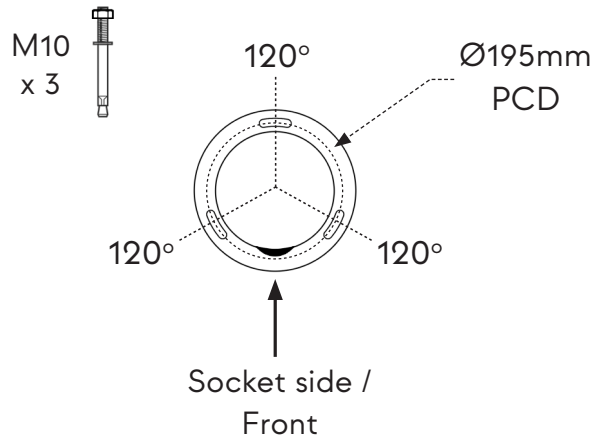
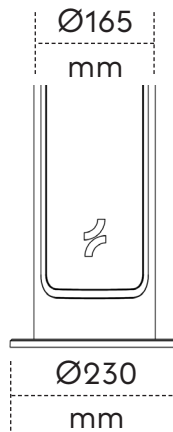
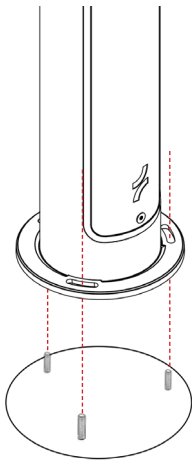

- Remove the front door using the H5 Pin Hex Allen key.

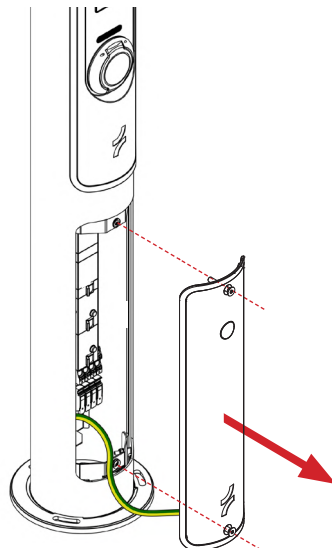

4. Install the Steel Wire Armoured (SWA) cable gland to the cable plate, ensuring the Earth tag (banjo loop) is affixed as shown below.

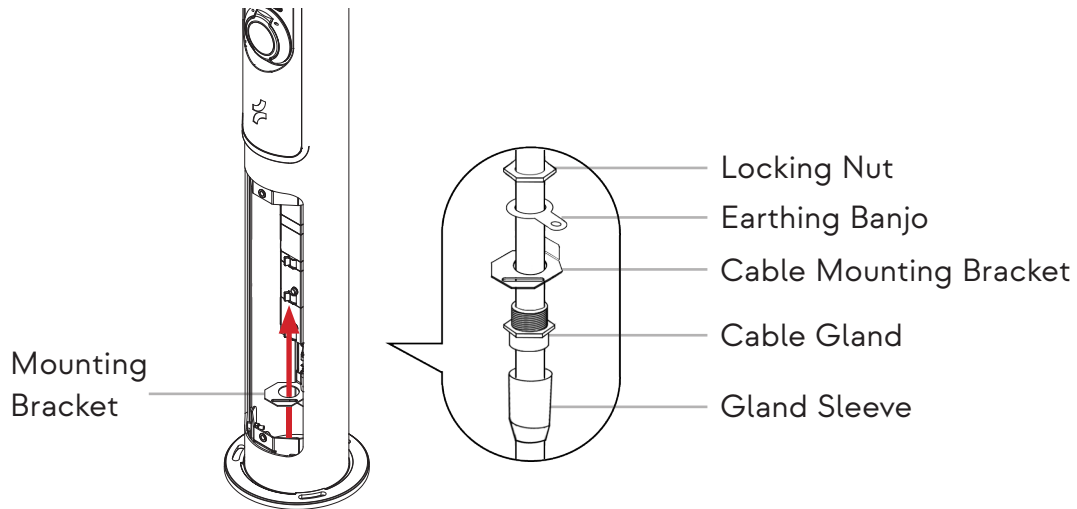

Note: Ensure SWA cable is connected to the Earth block using cable supplied.

5. Perform the insulation resistance tests prior to terminating to the io7.

⚠ WARNING Performing this test whilst the io7 is fully terminated could cause serious damage to the charger.

6. Terminate the Supply cables (up to 25mm²).

- Earth = Green/Yellow
 - N = Blue
 - L1 = Brown
 - L2 = Black*
 - L3 = Grey*
- a) Ensure the RCBOs are in the “on” position.
 b) Conduct all other relevant tests, as specified by local regulations.
- * for 3 phase installation only.

RCBO on position - Red

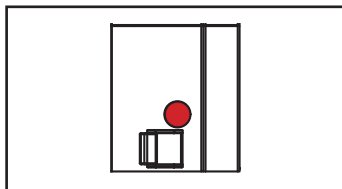

RCBO off position - Green

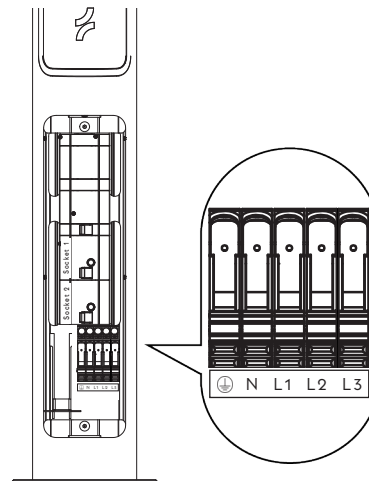
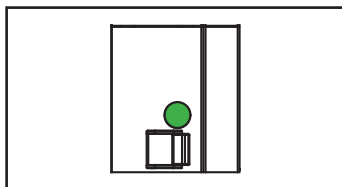

7. Close the door and secure using the H5 Pin Hex Allen Key. Ensure Earth cable is connected, remains intact and is not trapped when the door is repositioned and closed.

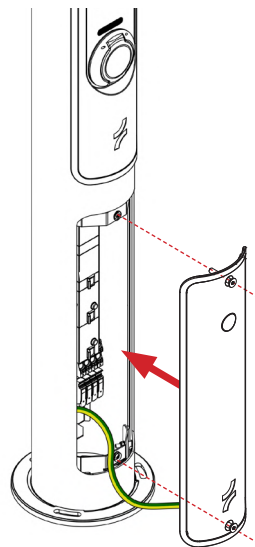

6. Commissioning the io7

6.1. Initial Steps

The installer must follow the next steps to prepare the io7 to be connected to the preferred communication method and third party back-end software.

The main sequence of steps are as follows:

1. The charger should be powered up. The LEDs will illuminate white whilst the charger is booting up. Once ready, the charger LEDs will turn green. At this point the user interface can be accessed. This will enable the charger's Wi-Fi Hotspot for 10 mins. If the log in process is not completed within this time frame, the charger must be rebooted.

2. Using a mobile device or laptop, search for the chargers Wi-Fi Hotspot as illustrated below using Password "Ratioio7"

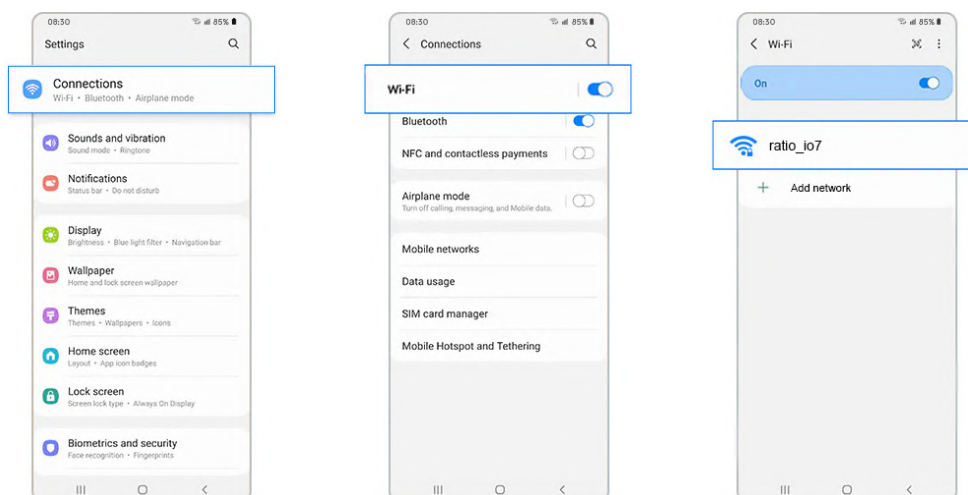

3. If using a laptop, navigate to the Wi-Fi settings on your computer and select "ratio_io7".

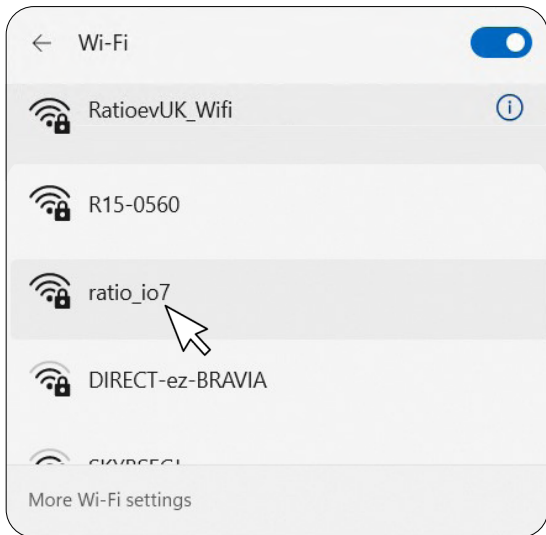

4. Select "Connect using a security key instead".



5. A new window will open. Click on the window and insert password "Ratioio7".

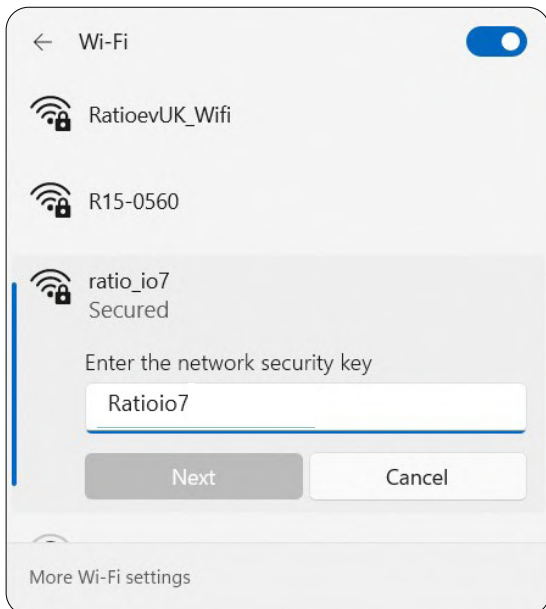

6. Select "Next".

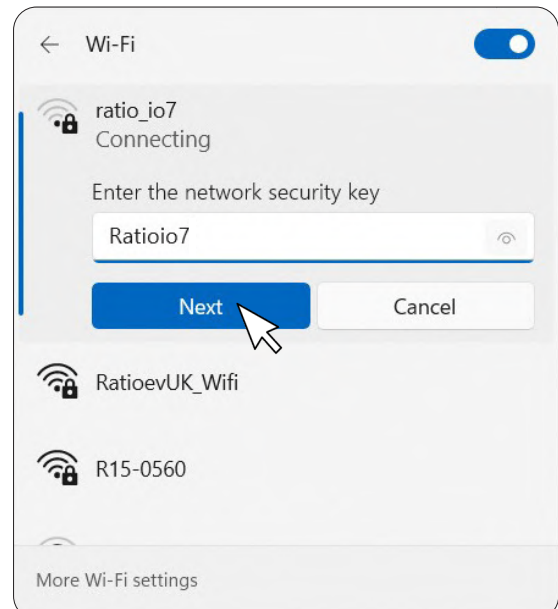

Note: If after entering the password you receive a message stating "Internet no connection" continue to step 7.

7. Open a web browser on a mobile device or laptop and input 10.7.10.7 into the URL search bar. This should take you to the page below. Alternatively, scan the QR code which will navigate you directly to the site.



Note: If this page appears, click on the “Advanced” option and select “Continue”.



Your connection isn't private

Attackers might be trying to steal your information from **10.7.10.7** (for example, passwords, messages, or credit cards).

NET::ERR_CERT_AUTHORITY_INVALID

Advanced

Go back

This will navigate you to the following page.

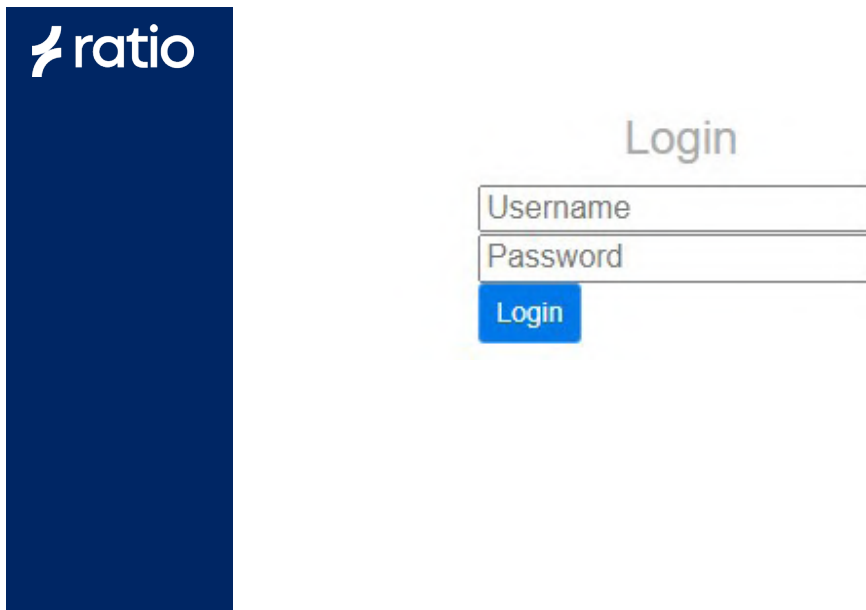

8. Log into your charger by inputting the username “Installer” and the password as "RatioInstaller".

9. Now navigate to the User Settings section and change the password to a memorable secure password and store in a safe location.

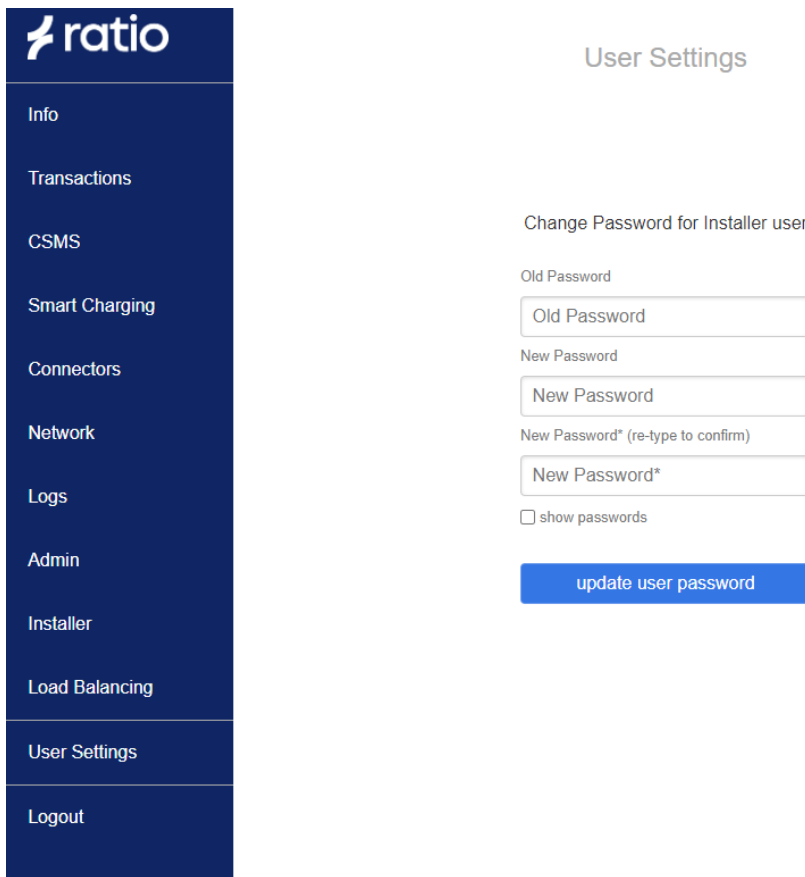

6.1.2. General Information Page

Once logged in, the general information screen (below) will show system details such as the charger make and model, the System IP Address and the Host name.

6.1.3. CSMS

1. Go to the CSMS tab on the left hand side of the page and define the devices parameter settings on the CSMS Server address.

For this, please follow the steps below;

The charger server connection status will be shown in this section. It will show “connected” or “disconnected” accordingly.

1. Ensure the toggle is set to “Authorisation via CSMS Server” if a back-end software is being used. If no back-end software (example image below) is required, set to “Local Authorisation” and proceed to Step 3.

2. The URL address of the selected back-end software should be added to this section. Example below.

3. Select your required RFID status.

Select “Save”.



Settings

CSMS Server Address

wss://ocpp.monta.app/

Example: If using a back-end software provider, (example on the left as Monta) the CSMS Server Address would be similar to the image shown on the left.

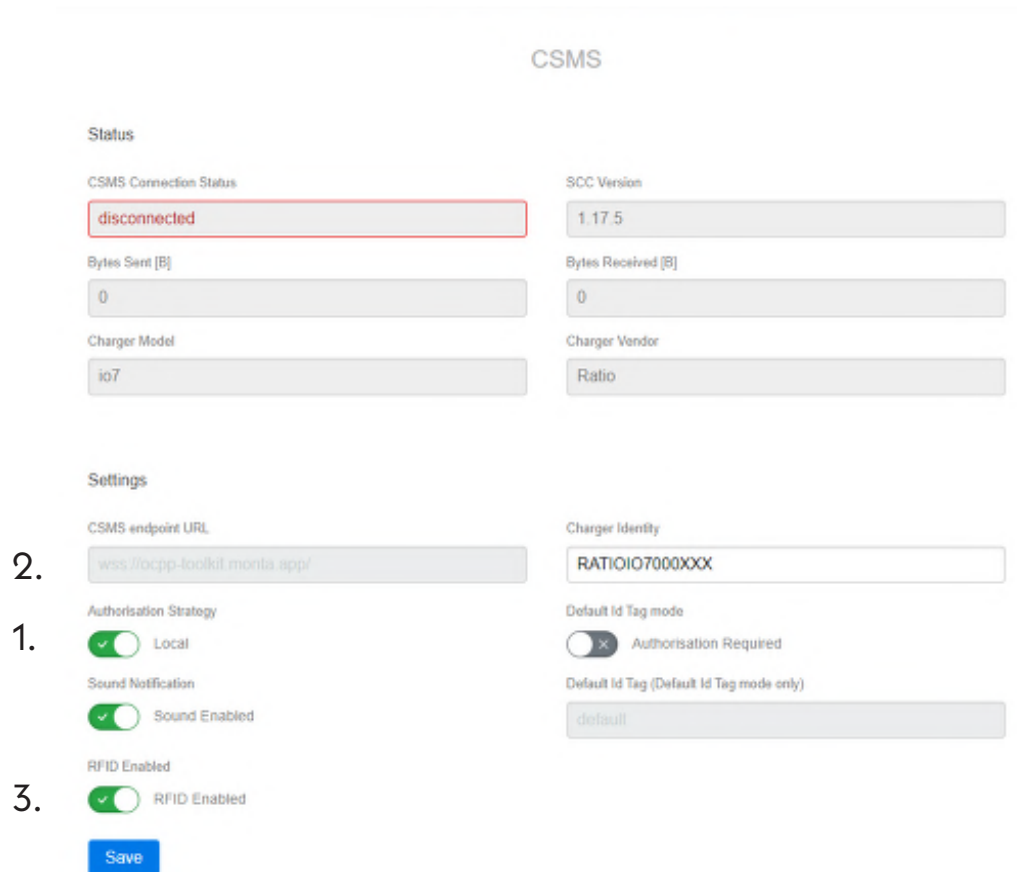
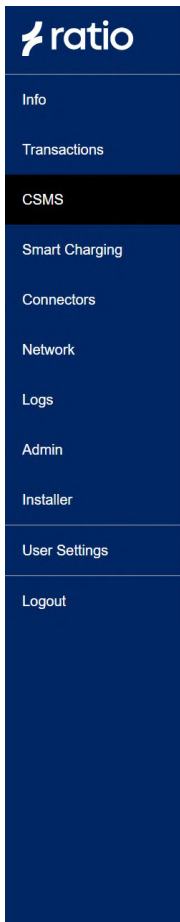

CSMS

Status

CSMS Connection Status: disconnected

Bytes Sent [B]: 0

Charger Model: io7

SCC Version: 1.17.5

Bytes Received [B]: 0

Charger Vendor: Ratio

Settings

CSMS endpoint URL: wss://ocpp-lookit.monta.app/

Authorisation Strategy: Local

Sound Notification: Sound Enabled

RFID Enabled: RFID Enabled

Charger Identity: RATIOIO7000XXX

Default Id Tag mode: Authorisation Required

Default Id Tag (Default Id Tag mode only): default

Save

2.

1.

3.

6.1.4. Network Settings/Parameters

Connectivity to the internet can be achieved by either using an Ethernet cable, Wi-Fi or 4G. Connect the device to the internet. Follow the steps shown below;

1. The toggle named DHCP will allow you to set either a Static or Dynamic IP dependant on requirements.

2. If Wi-Fi is required, enable the Wi-Fi toggle.

3. Select "Refresh list" to view available Wi-Fi networks and select your required one.

4. Input the Wi-Fi password.

Select "save".



Note: If you select "save + connect" the hotspot will be dropped.

Note: If using Ethernet or 4G the Wi-Fi toggle must be switched disabled.

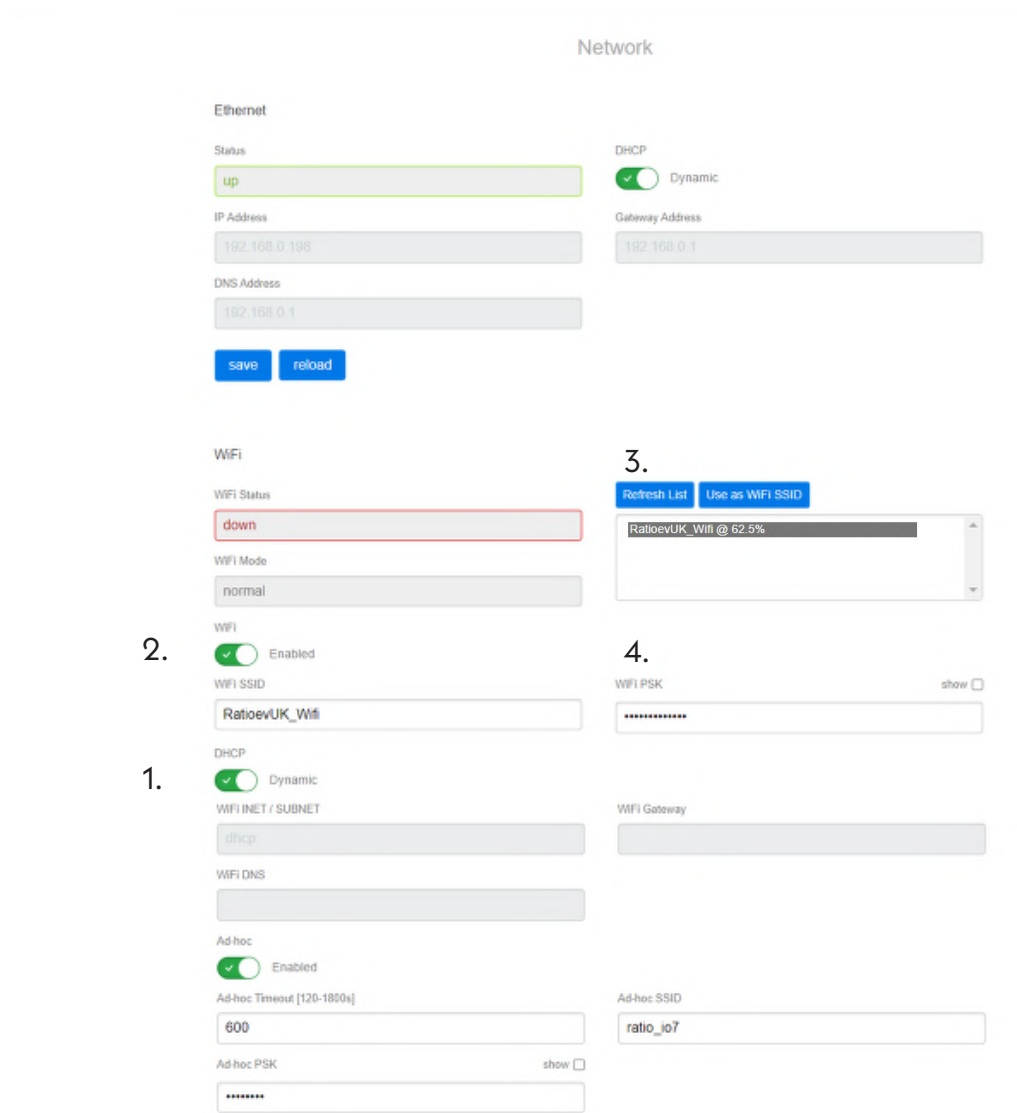

Note: Wi-Fi Ad Hoc configuration settings **must not** to be adjusted.

6.1.5. 4G Enabled

Navigate to the **Network** page as above and follow the steps below;

1. Toggle to dissable the Wi-Fi.



2. Ensure Ad-hoc LinkLocal remains enabled.



4. Select "Save".

Note: Ensure to Select the "Save" illustrated below.

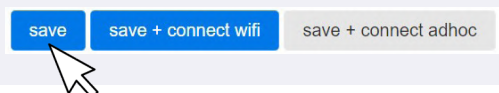

Note: If Ad-hoc is disabled, the Wi-Fi is left enabled or the Ethernet cable is not removed, the Wi-Fi or the Ethernet will override the 4G.

6.1.6. Ethernet Enabled

For Ethernet enabled option, ensure that the Ethernet cable is connected to your network and ensure the Wi-Fi toggle is dissabled in the **Network** page as per step 1. in section 6.1.5.

6.1.7. SIM Enabled

To configure the charger to use 4G, navigate to the **Network** page. and select "refresh modem info" as shown below.

1. Select "refresh modem info" as shown below.
2. Insert the back office details into the APN, Username and Password in the Modem Settings section and select "save".

The screenshot shows the Ratio Network management interface. On the left is a dark blue sidebar with the Ratio logo and a menu with items: Info, Transactions, CSMS, Smart Charging, Connectors, Network (highlighted), Logs, Admin, Installer, User Settings, and Logout. The main content area is titled 'Modem Status' and contains several data fields: ICCID (8944502011217488494f), IMSI (234500091748849), and IMEI (867280060333150). Below these are COPS (Automatic), RSSI (dBm) (loading...), and IoT Mode (loading...). Further down are Registration Status and EPS Registration Status, both showing 'loading...'. The 'Modem Testing' section includes SIM Status (loading...), IP (loading...), PING IP (8.8.8.8), and PING Test (loading...). Two blue buttons are present: 'restart modem (interface + service)' and 'refresh modem info', with a mouse cursor pointing to the latter and a '1.' next to it. The 'Modem Settings' section at the bottom has input fields for APN, Username, and Password, with a 'show' checkbox and a 'save' button. A '2.' is placed to the left of the APN field.

Once the refresh has completed, the Modem Testing section will reflect the SIM information.

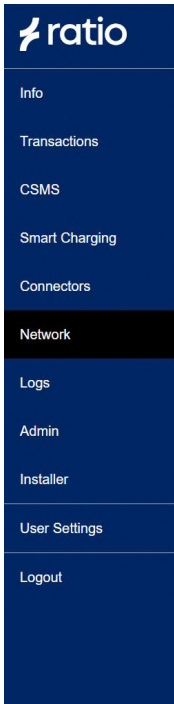

Modem Status

ICCID	IMSI	IMEI
8944502011217488494f	234500091748849	867280060333150
COPS	RSSI [dBm]	IoT Mode
Automatic		CAT-M

Registration Status

Disable network registration. Registered, roaming

EPS Registration Status

Disable network registration. Unknown

Modem Testing

SIM Status	IP	PING IP	PING Test
SIM OK	10.113.108.9	8.8.8.8	⇒ successful

restart modem (interface + service) refresh modem info

Modem Settings

APN	Username	Password	show <input type="checkbox"/>
XXXXXXXX	XXXXXXXX	XXXXXXXX	

save

Click "save".

6.1.8. Installer Settings

Navigate to the **Installer** page and follow the steps shown below;

1. Ensure the "Charger Settings "displays the correct time zone.
2. Add the maximum available current for the io7 on "Charger Current Limit [6-63A]". This value should be between 6 - 63A. This is the maximum available current within the installation.
3. Enter the Installer Name, Company and Email in the relevant cells.
4. Select the Phase connection to the charger from the drop down menu for EVSE1 and EVSE2.

Select "save all configuration + calibrate".

save all configuration + calibrate

Installer Settings

Charger Settings

1. Timezone

2. Charger Current Limit [5 - 63A]

Installer Info

3. Installer Name [text]
Installer Company [text]
Installer Email [email]

EVSE #1/2

Tilt/Bump Detection

Disabled Bump Acceleration [1 - 15g] Tilt Angle [1 - 80°]

4. Phase Settings
Installer Phase Selection
Phase Connection (v1)

External Metering

External CT Clamps
 Disabled

EVSE #2/2

Tilt/Bump Detection

Disabled Bump Acceleration [1 - 15g] Tilt Angle [1 - 80°]

Disabled Bump Acceleration [1 - 15g] Tilt Angle [1 - 80°]

Phase Settings

Installer Phase Selection
Phase Connection (v1)

External Metering

External CT Clamps
 Disabled

6.1.9. Smart Charging

Click on the **Smart Charging** tab on the left and follow the steps below;

1. Use the toggle to enable or disable Smart Charging. If disabled, refer to step 7.

Note: The io7 complies with the UK Smart Charging Regulations. If charging is required during peak hours, smart charging must be disabled using the toggle switch. See point 3 for adjusting the delayed start.

Note: When enabled, no charging will take place within the set times.

2. Set the no charging periods.

3. The randomised delay is set to 600 seconds. This setting forces the charger to offer power to a vehicle anywhere between a 0 and 10 minute interval. The randomised delay can be overridden if required for instantaneous charging. To do this, insert 0 into the box.

Select "Save".

The screenshot shows the Ratio web interface for Smart Charging configuration. On the left is a dark blue sidebar with the Ratio logo at the top and a list of menu items: Info, Transactions, CSMS, Smart Charging (highlighted), EVSE, Network, SCC, LED, Admin, Installer, Assembler, and Security. The main content area is titled "Smart Charging" and contains the following settings:

- Smart Charging Profiles**
 - Number of Active Profiles: 0
 - Number of Charging Profiles: 0
 - Clear button
- Default Charging Profile**
 - Default Profile: Disabled (toggle switch)
 - When Enabled, No charging happens during these periods:
 - No charging Period 1: from 08:00 to 11:00
 - No charging Period 2: from 16:00 to 22:00

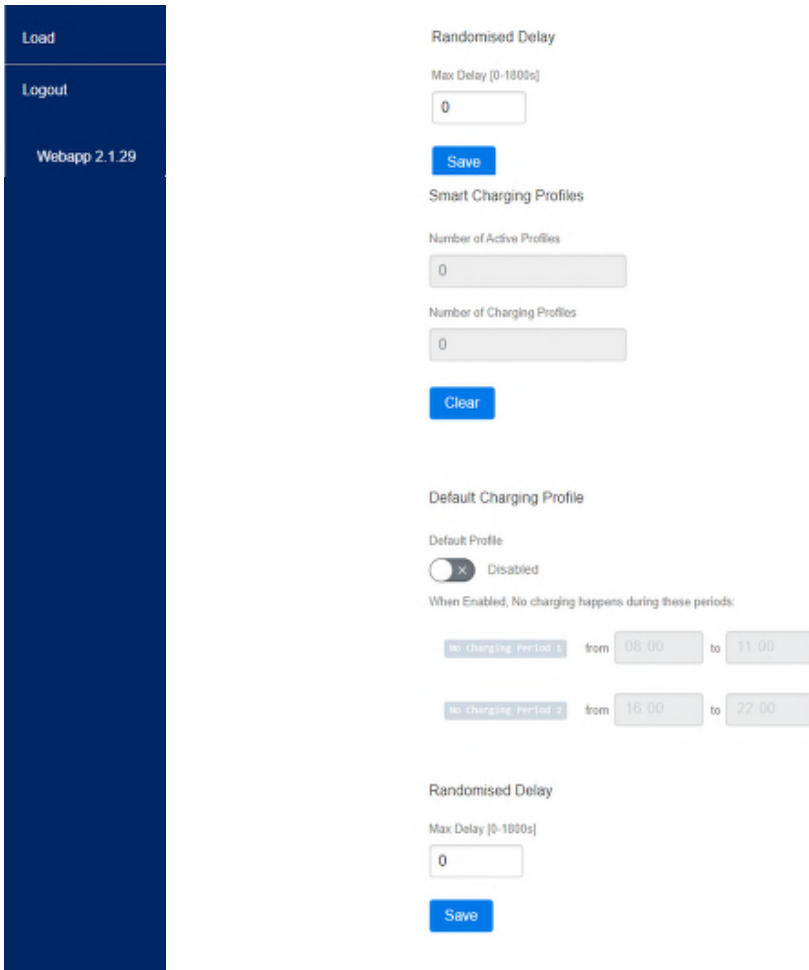

4. Click on "Logout" on the left hand column and select "log out + drop adhoc".

6.2. Back-end software Provider

The io7 will now be visible to the back-end software. The back-end software instruction should be followed to finalise the commissioning.

Note: Before the charger is ready for use, it will require the full configuration process.

7. io7 Power up

Upon powering up, the io7 lights will turn on and light up white. Once this has been completed, the lights will turn Green when powering up has been completed.







The LEDs on the io7 provides the user with a visual representation of the chargers status. For futher colour codes, please refer to the table in Section 3. Technical data (page 12).

For trouble shooting colour codes, please refer to table in Section 8. Troubleshooting.

Note: If the LEDs are **Red**, the fault will be reported via OCPP to the back-end software. Consult the back-end software fault logs, or if the problem persists contact Ratio for remote assistance.

8. Troubleshooting

The charger is equipped with monitoring software that detects faults and reports these through Open Charge Point Protocol (OCPP) via the back-end software. In the event of experiencing problems with your charger, please contact the back-end software provider to assist and solve the issue.

Colour sequence	LED colour description	Status
 	Red / White	Card not authorised
  	Red / White / Blue	Error bump detected
 	Red / Green	Error control pilot voltage
  	Red / Blue / Magenta	Error current leakage
 	Red / Blue	Error diode
  	Red / Magenta / Green	Error ee prom corrupt
 	Red / Yellow	Error general
  	Red / White / Yellow	Error high temperature
 	Red / Magenta	Error meter read time out
  	Red / Blue / Magenta	Error current failure
  	Red / White / Green	Error over/under voltage
  	Red / Green / Blue	Error reader failure
  	Red / Blue / Yellow	Error reset failure
  	Red / Yellow / Magenta	Error under current
 	Green / Blue	Firmware update
 	Magenta / Yellow	Inoperative
 	White / Magenta	RFID white list mode
 	Magenta / Blue	Suspended EV
 	Magenta / Blue	Suspended EV Seb
 	Magenta / Blue	Suspended EV Sec
 	Yellow / Green	Tamper state

9. Use

9.1.1. Start Charging through back-end software

Charging sessions can be started by using the back-end app.

9.1.2. Start Charging RFID

In order to enable users to charge vehicles using RFID, the settings must be adjusted within the back-end software provider and enable the RFID feature.

Once activated, simply plug the charging cable into the io7 and the vehicle, and activate the charging session by swiping your RFID tag.

To begin your charging session;

1. Plug the charging cable into a socket on the io7.
2. Plug the vehicle connector side of your charging cable into your vehicle.
3. The light correspondent to your charge point will turn from Green to Magenta to indicate that the EV is detected.
4. Swipe your RFID tab onto the reader to activate charge. The LED should turn from Purple to Yellow, to indicate waiting for vehicle or back-end software. Once the vehicle begins to charge, the light will go from Yellow to pulsing Blue, to signify that your vehicle is being charged. Once the session is complete, the lights will flash Blue to Magenta to indicate the end of charge.

9.2. During charging

During a charging session, the measured charge times and power usage will be displayed in kW in your back-end software App.

9.2.1. Charging paused

In case there is less than 6A available on the main grid, the charging session will automatically be paused.

Switch off any power demanding devices or wait until more than 6A power is available.

As soon as there is sufficient available power, the charging session will automatically resume.

9.3. Stop charging

The charging session will stop automatically when the vehicle is charged to the maximum battery level, set within the EV.

You can also manually stop the charging session through your chosen back-end software app by or by swiping your RFID tag (if applicable) over the reader again or by unlocking the vehicle.

1. Unplug the EV charging connector from the EV.
2. Unplug the EV Charging connector from the io7.

The back-end software App will no longer show current directions and power usage values.

10. Maintenance

Ratio chargers are practically maintenance-free, aside from periodic cleaning of the housing.

1. Switch off the charger before cleaning the housing.
2. Clean the io7 using a soft cloth lightly moistened with mild detergent solution.

WARNING

Risk of electric shock

- Switch off the charger before cleaning the housing.
- Be careful when cleaning the inlets and socket, do not use excessive amounts of water to avoid water leaking into the charger.

11. Service

To avoid risk of electric shock, only qualified electricians should perform service or maintenance on the charger. If your charger is in need of servicing, please contact Ratio, your local vendor or a qualified electrician.

12. Data protection

Please refer to the privacy statement on the Ratio website at www.ratioev.uk

13. Warranty

Ratio EV Charging warrants this product to be free from defects in material, manufacture and design for a period of 3 years after the date of purchase. If this product is defective in materials, manufacture or design during this warranty period, Ratio EV Charging will, at its option, repair or replace the product.

Repair parts and/or replacement products may be either new or reconditioned at the discretion of Ratio EV Charging.

This limited Carry-In Warranty does not include service to repair damage from improper installation, improper connections with peripherals, external electrical fault, accident, disaster, misuse, vandalism, unauthorized alteration or repair, abuse or modifications to the product not approved in writing by Ratio EV Charging.

Any evidence of an attempt to disassemble the io7 Charger will void this warranty.

Any service repair outside the scope of this limited warranty shall be at applicable rates and terms then in effect.

14. Disposal



If the charger is defective beyond repair, or you no longer wish to use the charger, please recycle the charger according to Ratio's Terms and Conditions of recycling WEEE products.

15. EC Declarations of Conformity



Declaration of Conformity

Manufacturer: Ratio EV Ltd
Date: 01/01/2023
Address: Unit 1 Target Park, Shawbank Road, Lakeside, Redditch, Worcs, UK, B98 8YN
Product: iO7 EVSE Charing Pillar
Model/Type: IO71PXXX, IO73PXXX.

We declare that the above stated product range is in conformity with the provisions of the following statutory requirements, including all amendments, and with national legislation implementing these regulations:

2014/35/EU	LCD - Low Voltage Directive
2014/30/EU	EMC - Electromagnetic Compatibility
2011/65/EU	RoHS - Restriction of Hazardous Substances in Electrical and Electronic Equipment.
EC 1907/2006	REACH – Registration Evaluation, Authorisation and Restriction of Chemicals

All products are manufactured in accordance with our ISO9001 quality system and are 100% tested for safety and operation during production.

Reference	Type
BS EN IEC 61851-1:2019	Electric Vehicle Conductive Charging System General Requirements
BS EN IEC 61851-21-2:2021	Electric Vehicle Conductive Charging System Electric Vehicle Requirements for Conductive Connection to an AC/DC Supply. EMC Requirements for Off Board Electric Vehicle Charging Systems
BS EN IEC 61000-6-1:2019	Electromagnetic compatibility (EMC). Generic standards. Immunity standard for residential, commercial, and light-industrial environments
BS EN IEC 61000-6-3:2021	Electromagnetic compatibility (EMC). Generic standards. Emission standard for equipment in residential environments
BS 7671:2018+A2:2022	Requirements for Electrical Installations. IET Wiring Regulations.

Name and signature of authorised person

Tom Jennings – General Manager





Declaration of Conformity

Manufacturer: Ratio EV Ltd
Date: 01/01/2023
Address: Unit 1 Target Park, Shawbank Road, Lakeside, Redditch, Worcs, UK, B98 8YN
Product: iO7 EVSE Charging Pillar
Model/Type: IO71PXXX, IO73PXXX.

We declare that the above stated product range is in conformity with the provisions of the following statutory requirements, including all amendments, and with national legislation implementing these regulations:

UK SI 2016 No. 1101	The Electrical Equipment (Safety) Regulations 2016
UK SI 2016 No. 1091	Electro Magnetic Compatibility Regulations 2016
UK SI 2012 No. 3032	Restriction of the use of Certain Hazardous Substances in Electrical and Electronic Equipment Regulations 2012.

All products are manufactured in accordance with our ISO9001 quality system and are 100% tested for safety and operation during production.

Reference	Type
BS EN IEC 61851-1:2019	Electric Vehicle Conductive Charging System General Requirements
BS EN IEC 61851-21-2:2021	Electric Vehicle Conductive Charging System Electric Vehicle Requirements for Conductive Connection to an AC/DC Supply. EMC Requirements for Off Board Electric Vehicle Charging Systems
BS EN IEC 61000-6-1:2019	Electromagnetic compatibility (EMC). Generic standards. Immunity standard for residential, commercial, and light-industrial environments
BS EN IEC 61000-6-3:2021	Electromagnetic compatibility (EMC). Generic standards. Emission standard for equipment in residential environments
BS 7671:2018+A2:2022	Requirements for Electrical Installations. IET Wiring Regulations.

Name and signature of the authorised person

Tom Jennings – General Manager





Ratio EV Charging,
Unit 1 Target Park,
Shawbank Road,
Lakeside,
Redditch,
Worcestershire
B98 8YN

+44 (0) 1527 396 900
ratioev.uk
info@ratioev.uk